

Quantum Communications Research at CONNECT

Dan Kilper
Trinity College Dublin

HOST INSTITUTION



Trinity College Dublin
Coláiste na Tríonóide, Baile Átha Cliath
The University of Dublin

PARTNER INSTITUTIONS



University College Dublin
An Coláiste Ollscoile, Baile Átha Cliath



Waterford Institute of Technology

FUNDED BY:



Intersection of Quantum & Classical Networks

- Quantum transmission & network control planes
 - Quantum and classical signal coexistence
 - Multipartite entanglement and discord
 - Quantum repeater networks
- Quantum Enhanced Security & Applications
 - QKD, KMS integration
 - Tokens, coins, QRNG

Quantum & Satellite Communications Working Group



Emerging Research Area in CONNECT

Activity

- 5 funded projects
- 5 proposals under consideration (~€2.5M), with 2 more in train (~€16M)
- 6 associated projects (6 x PhD students)
- SFI STEAM Art Collaboration – rotation relay*
- ESERO SFI CanSat (secondary schools)

GOALS

- To pioneer quantum / classical network transmission systems and their control for terrestrial and satellite communications.
- Establish a ground to satellite research link in Ireland.
- Establish a quantum communication research network in Ireland.

*<https://www.sfi.ie/engagement/art-collaboration/rotation-relay/>

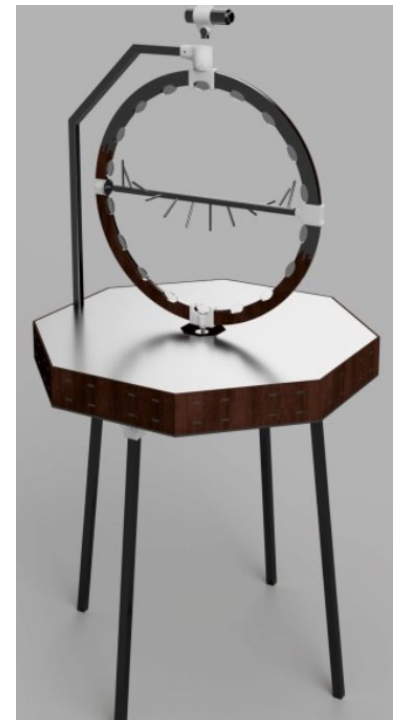

Quantum Communications



Quantum Internet

Its not (just) QKD – entanglement & discord across all areas below

Satellite Quantum Networks

International / Global links.

Quantum Physical Systems

Cryogenic / Quantum PIC
Interfaces to Networks

Quantum Sensor Networks

Nano-scale imaging.

Quantum (assisted) Services

QKD, PQA, Quantum Money, etc.

Quantum Data Centre Networks/Services

Quantum Servers, Quantum Tokens, etc.

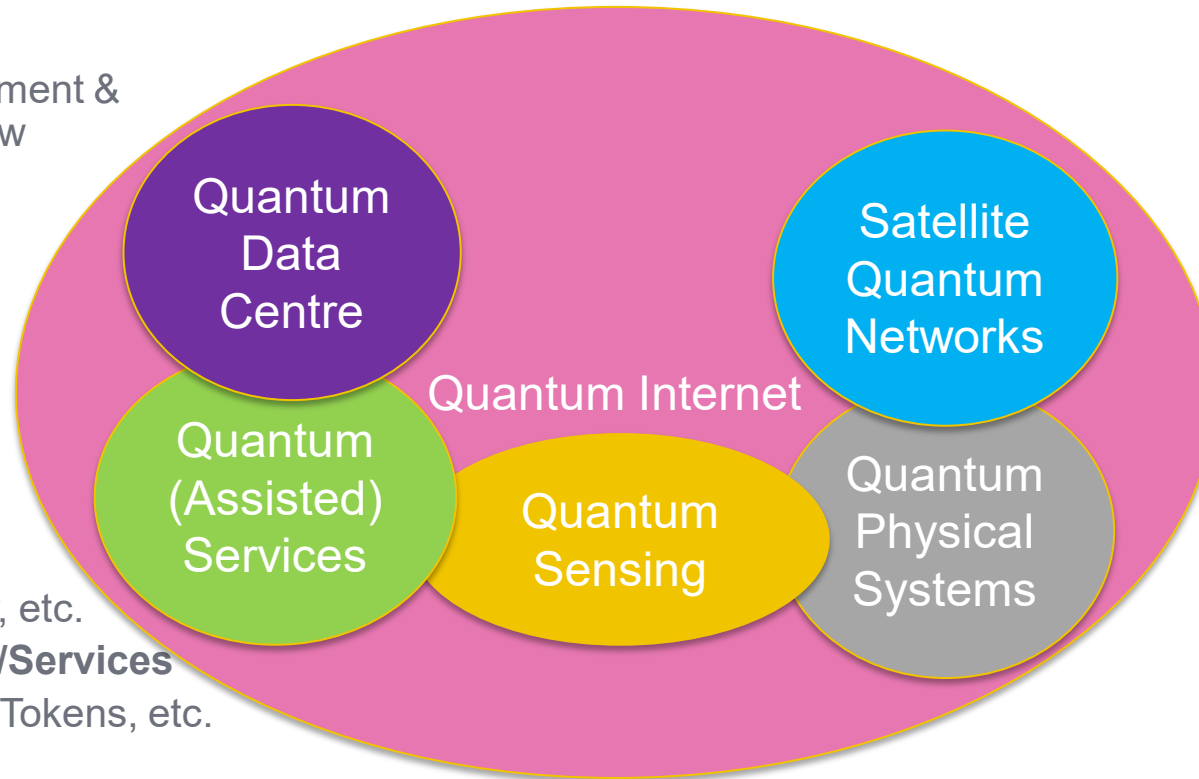

Ireland QCI Network

Metro Dark Fibre Networks

- MDI-QKD, Entanglement Distribution, Quantum Repeaters
- Long distance links between each city

HEAnet connection to Belfast



Dublin

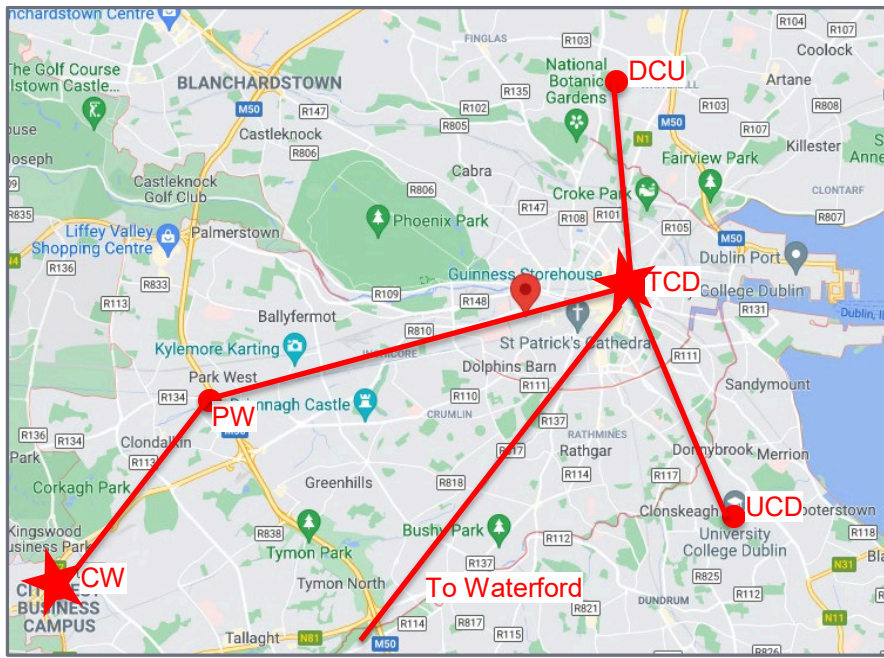

Waterford

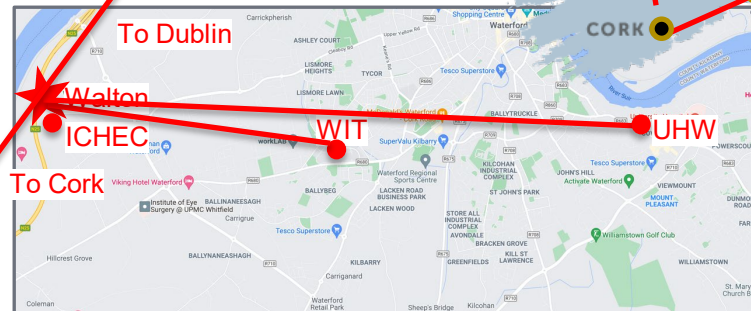

Cork

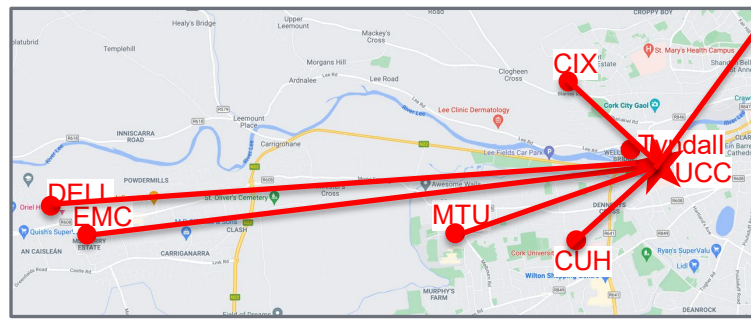

Mininet Quantum



Consortium: TCD, QUB, U. Arizona, Harvard

Mininet Quantum

Quantum Circuit Simulation

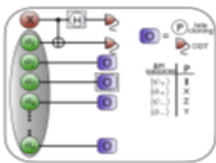

+

Quantum Network

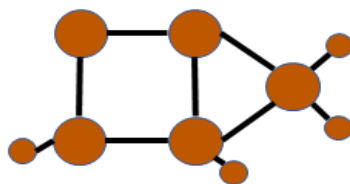

+

Quantum System Models

- Non-Markovian Systems
- Quantum Noise
- Decoherence Effects
- Loss/Propagation Effects
- Quantum/Classical Coexist.
- Time Synchronization

+

Mininet Optical

Mininet Data Network

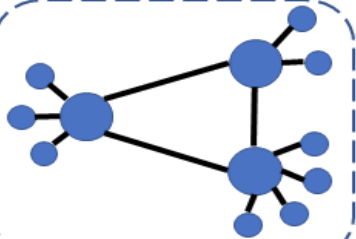

+

Physical Fiber Network

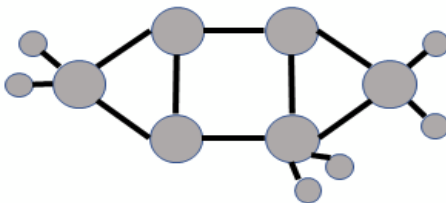

+

Transmission Simulation

- ASE Noise
- Nonlinear Noise
- Raman Scattering
- Propagation Effects
- Crosstalk

Mininet Quantum



- **Goal:** move from the quantum circuit simulation world shown in (a) to the network implementation world illustrated in (b)
- **Facilitate engineering approaches to quantum transmission systems & networks**

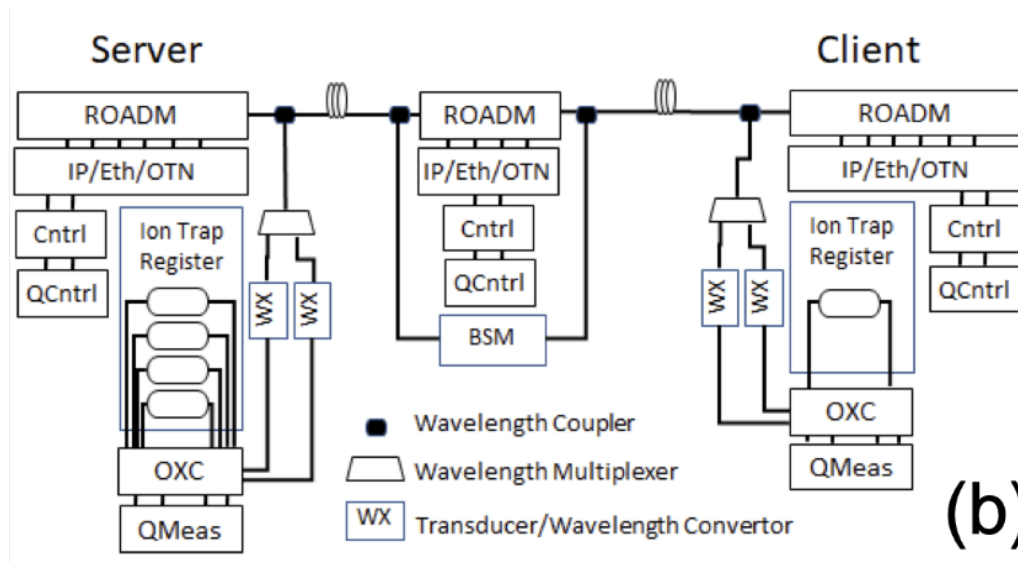
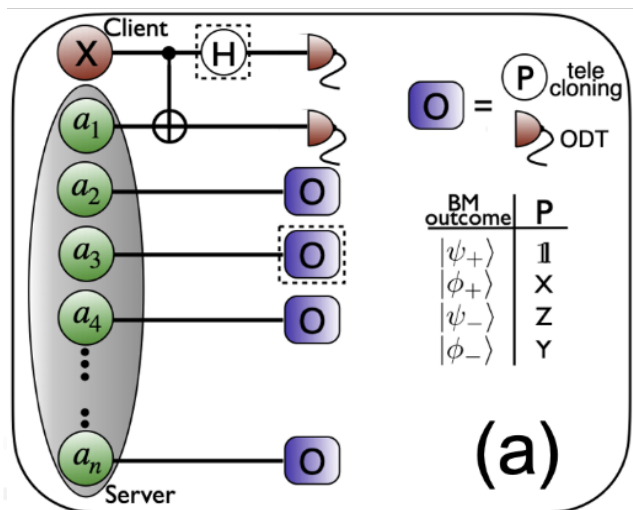

Convergent Quantum REsearch Alliance in Telecommunications: CoQREATE

SFI+DFE+NSF US-Ireland Centre to Centre Program

CQN: U. Arizona, MIT, Harvard, Yale, N. Arizona, U. Mass., Howard, U. Oregon, BYU, U. Chicago; QTeQ: Queens U. Belfast; CONNECT: TCD, UCD, UCC, Tyndall, DCU, Maynooth, U. Limerick, SETU, MTU, TUD

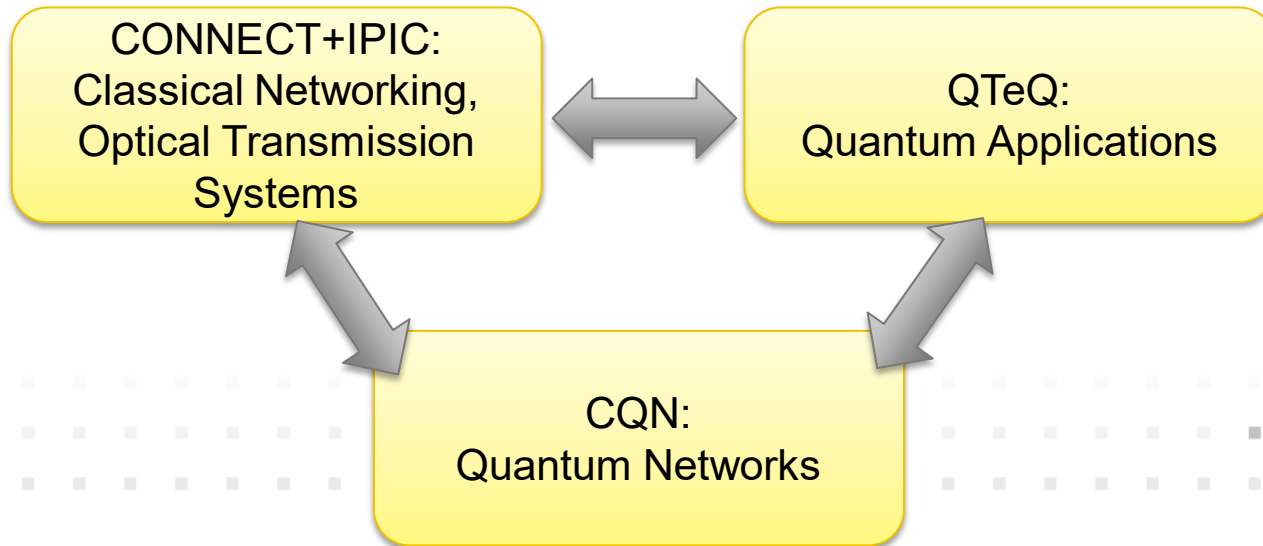

Goals & Objectives



- Foster deep collaboration between quantum and classical networking communities
- Bring centre-scale research to critical interdisciplinary challenges for terrestrial & satcom-assisted quantum networks
 - Coexistence and transmission technologies and design
 - Network control and architectures
 - Device packaging and interfacing
 - AI/ML network control and design
 - Satellite communication assisted quantum networks

Vision

Integrated SDN Control

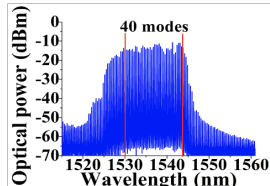
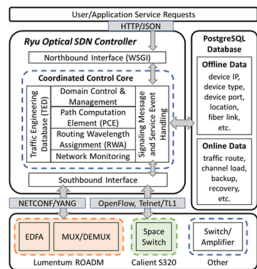

Tunable wideband interfaces



Heralded Entanglement via Satcom

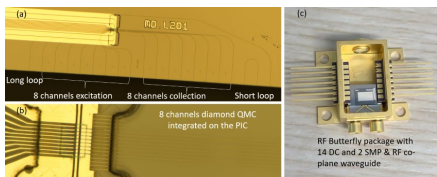
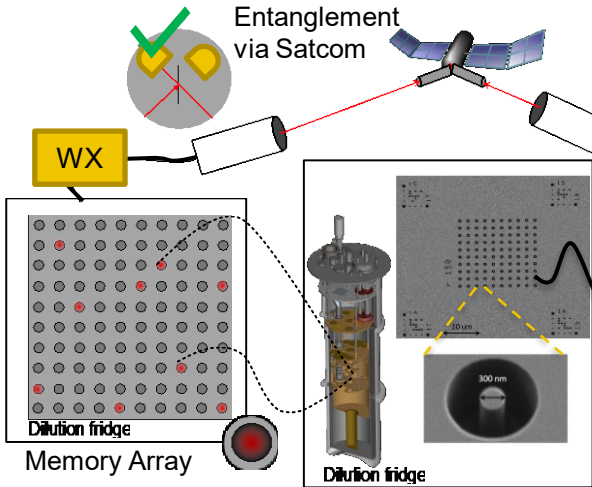

Photonic & Electronic ICs & Cryogenic SoCs

- Wavelength coupler
- WX Wavelength convertor
- BSM Bell State Measurement

Separate Transmission

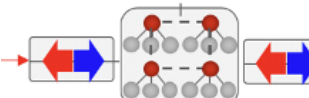
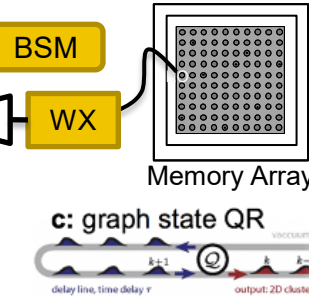
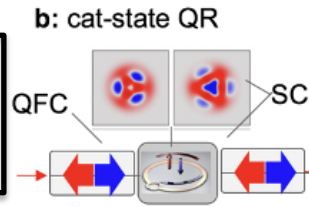
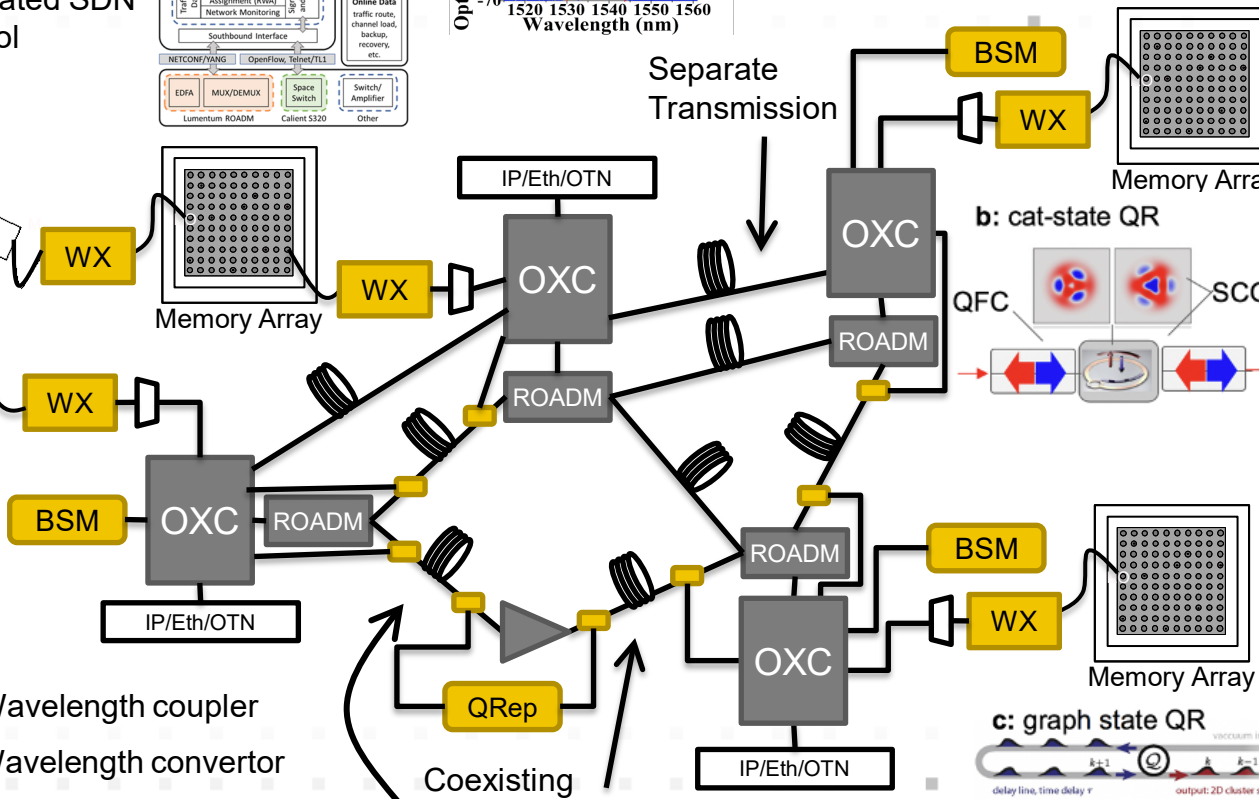

Core Network Technologies



- Packaging of PICs for Quantum Networks
 - Room temperature photonic & electronic ICs (O'Brien, Englund, Paternostro)
 - Thermo-mechanically stable cryogenic SoCs (Englund, O'Brien)
- Node and Link Technologies
 - Wideband (comb) interfaces and frequency conversion (Barry, Donegan, Paternostro, Jiang)
 - Purification considering optical transmission constraints (Jiang, Barry, Donegan, Paternostro)
 - Hardware efficient quantum error correction (Jiang, Guha, Flanagan)
 - Quantum channels using separable carriers (Paternostro, Kilper)
- Networking and Architectures
 - Multicast networks vs multiparty entanglement (Towsley, Guha, Paternostro)
 - Quantum & classical system capacity (coexistence) (Guha, Paternostro, Kilper)
 - Classical control for quantum repeater networks (Kilper, Towsley)

Cross-Cutting WPs



- AI Design & Control (DNNs, ELMs)
 - Entanglement routing & sharing state information (Claussen, Paternostro)
 - Quantum performance monitoring: characterizing & certifying quantum states and tomographic information (Zhuang, Paternostro)
 - Network level large scale multipartite entanglement (Paternostro, Claussen, Zhuang)
- Satellite Assisted Quantum Networks
 - Atmospheric characteristics of signal propagation (Kilbane, Englund)
 - Architectures for quantum satellite networks (Guha, Paternostro)
 - Satellite component design (Kilbane, Paternostro)

Convergent Research



- Two Western Cultures of Privacy: A Socratic Dialogue Across the Atlantic (Bambauer, Kilper)
 - 4 year staged program involving teams of students, faculty, and industry partners
- Diagram Reading Groups (Kilper, Bambauer)
 - Discussing multi-disciplinary figures and interpretations
- CoQREATEing Fictions Workshops (Kilper, Bambauer)
 - Constraint based writing
- Virtual and face to face sessions at plenary/annual meetings and conferences
- Coordinated with exchanges and visits



Quantum Activities: North & South

- Networks can become a virtual and physical bridge between quantum research north and south
- Quantum Internet: tremendous potential for growth
- CONNECT is ready partner on any and all aspects of quantum networking research
 - Basic research, simulation, applications
 - Education, public engagement, training



Thank you!



connectcentre.ie



[@connect_ie](https://twitter.com/connect_ie)



[connectcentre](https://www.linkedin.com/company/connectcentre)



info@connectcentre.ie